

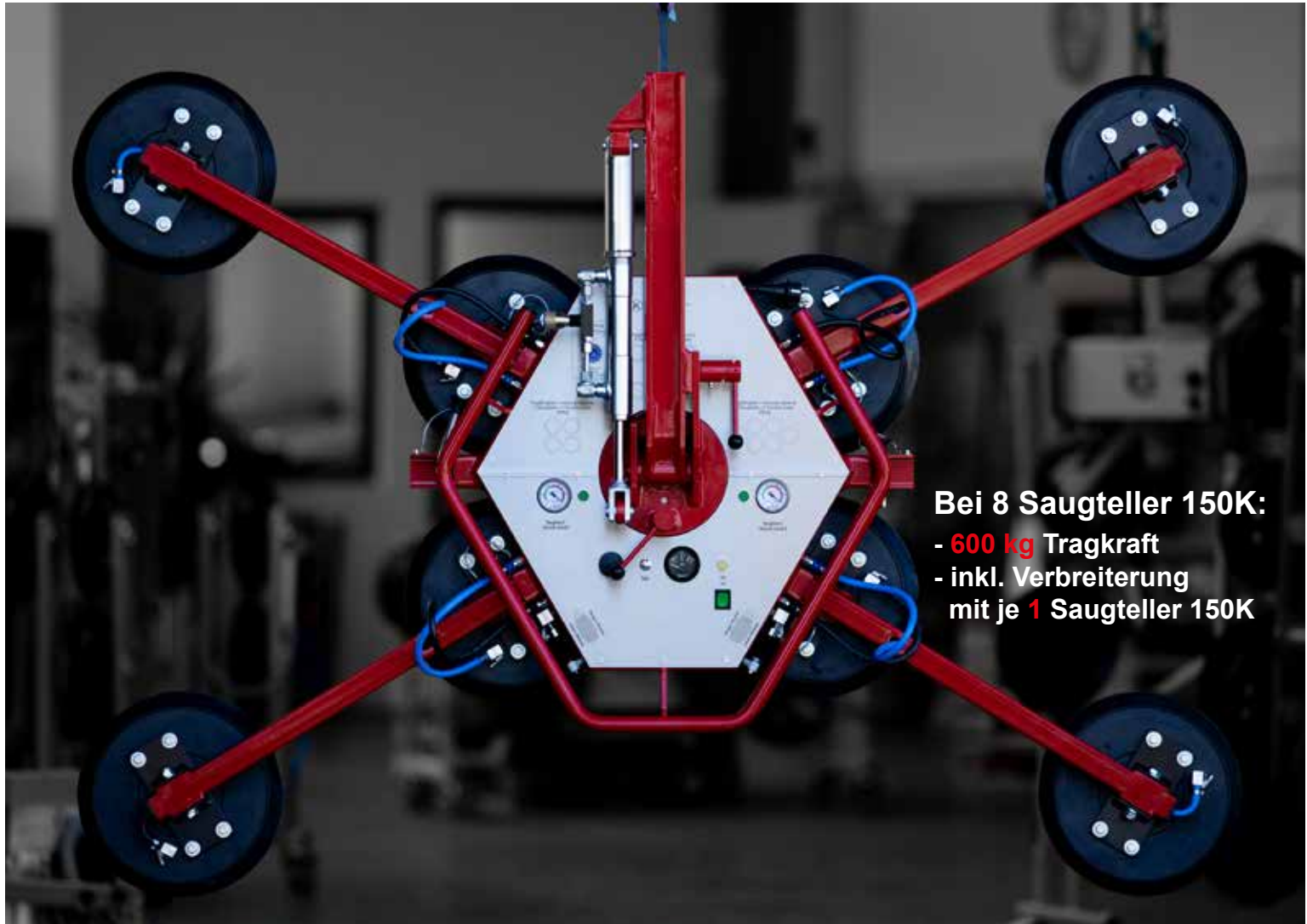

DSKZ2 - 12V

nach EN13155 / max. 600 kg Tragkraft



Bei 8 Saugteller 150K:
- 600 kg Tragkraft
- inkl. Verbreiterung
mit je 1 Saugteller 150K

Technische Daten:

- 12 V Batteriebetrieb
- Vakuumtank
- Manuell Drehen 360°
- Zweikreissauganlage
- Spannungsanzeige
- Manuell Kippen 90°
- Warneinrichtung
- Ladegerät

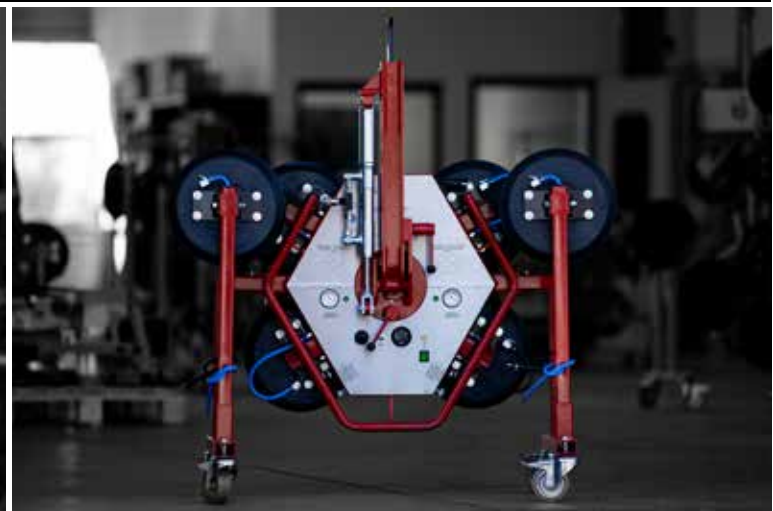
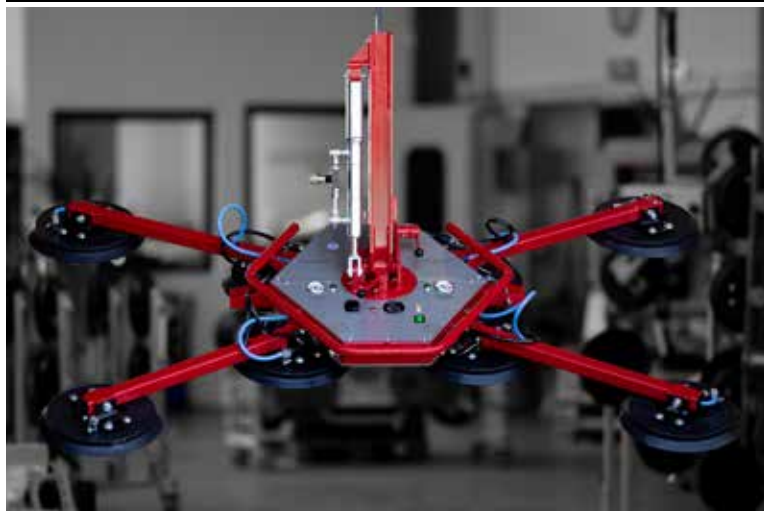

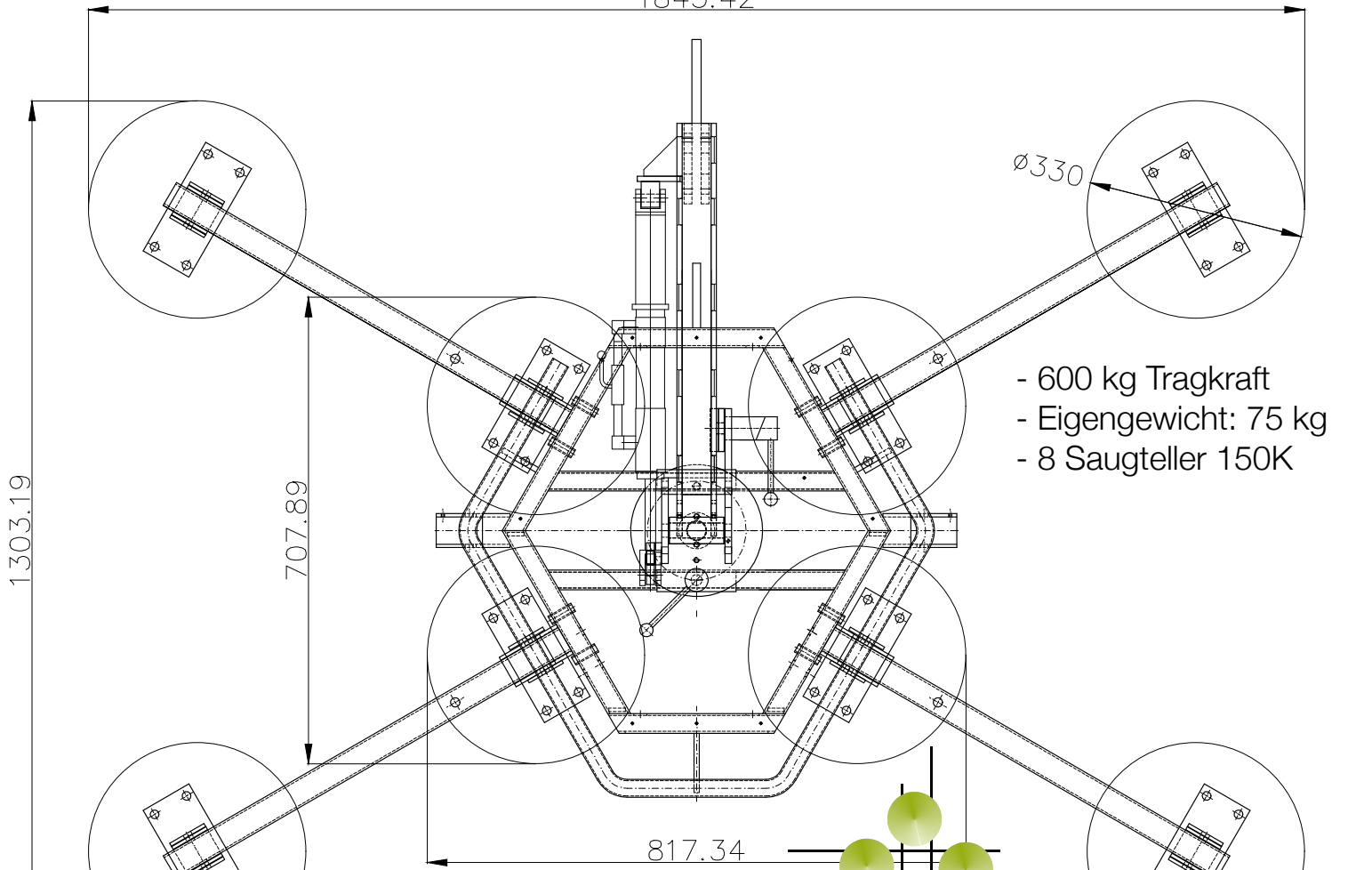

- 600 kg Tragkraft
- Eigengewicht: 75 kg
- 8 Saugteller 150K

Robert
Kappel GmbH

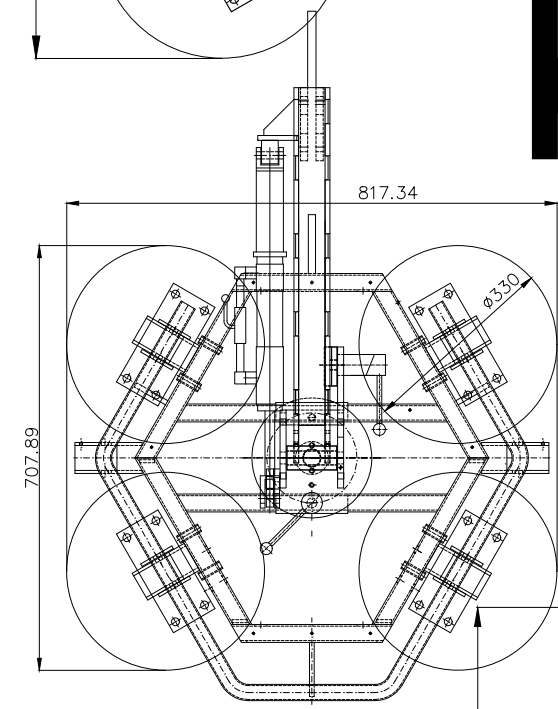

- 300 kg Tragkraft
- Eigengewicht: 55 kg
- 4 Saugteller 150K

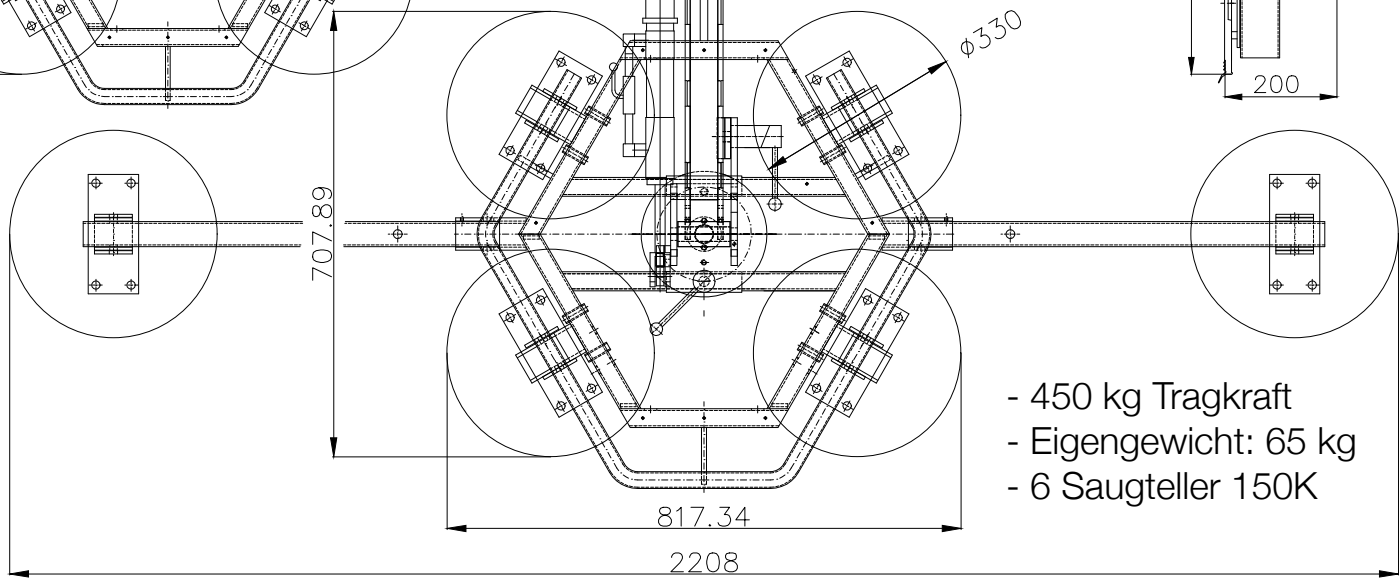
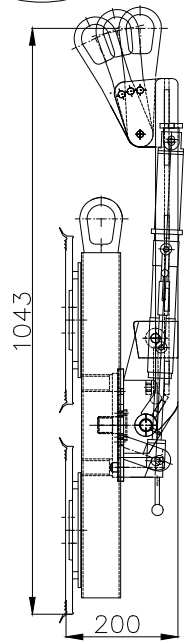

- 450 kg Tragkraft
- Eigengewicht: 65 kg
- 6 Saugteller 150K